



VENTURE
LIGHTING



HARTLAND HIGHBAY

Reaching New Heights In Industrial Illumination

Reaching New Heights

Efficient and **Eco-Conscious**

The Hartland has been crafted with warehousing requirements at the forefront of the design process. At 155lm/W, we're delivering energy savings that drive us, and our customers, towards a sustainable future. With a lifetime of 100,000 hours, this ensures your lighting is reliant and sustainable for many years to come. Making this a smart investment!

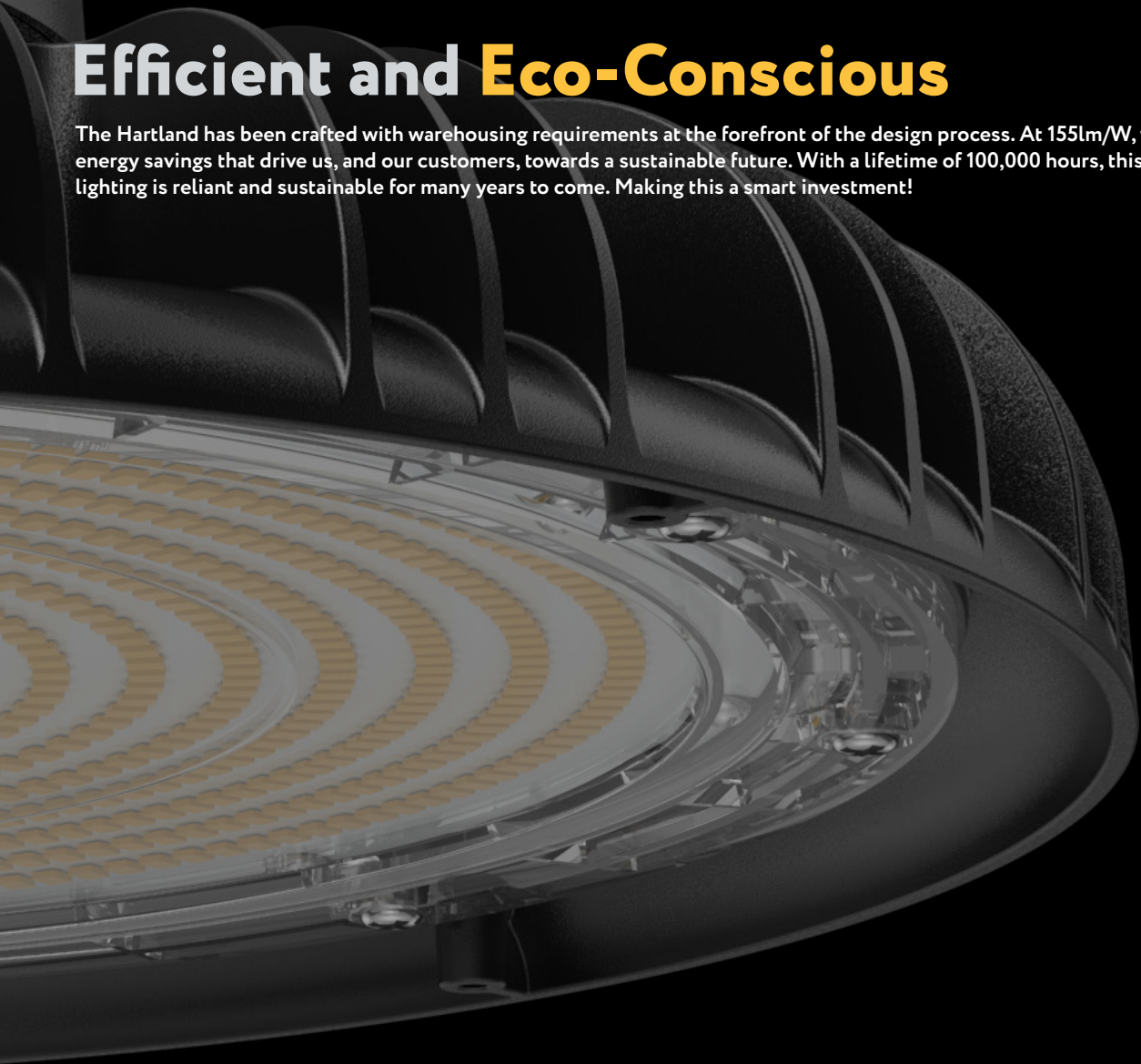

Switchable CCT & Wattage

The Hartland luminaire boasts both switchable CCT and Wattage. This feature provides versatility and flexibility, allowing for customisation to suit varying lighting needs and preferences.

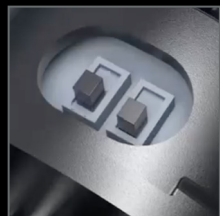

IND253 **IND257**
 80W 120W 150W 150W 200W 240W
 4000K 5000K 5700K

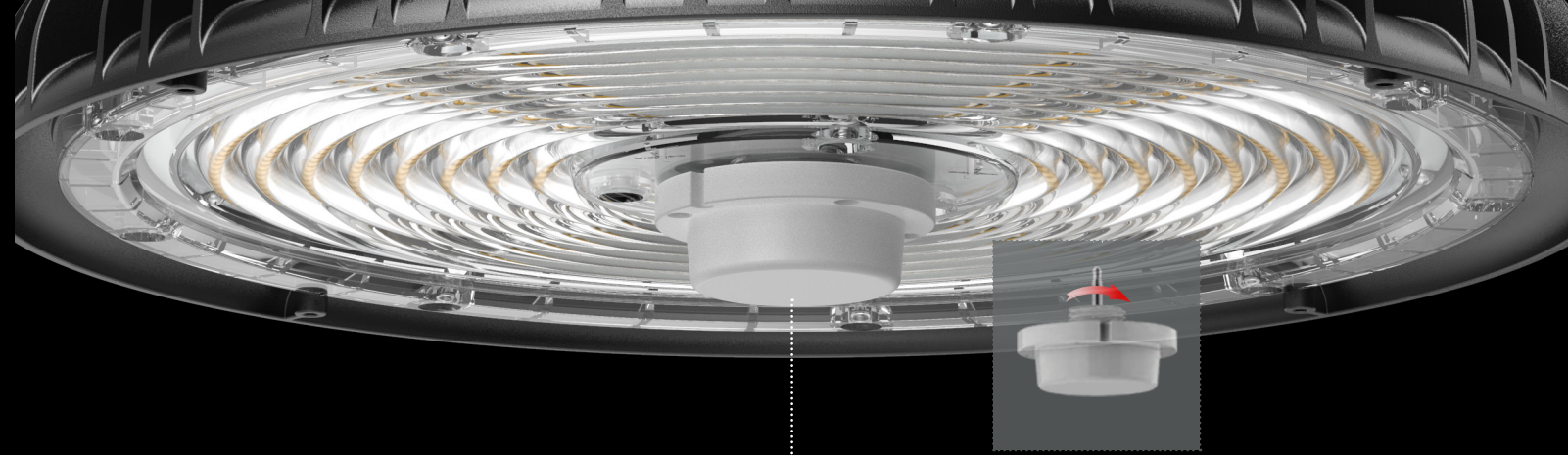

Plug and Play Microwave Sensor

With a plug and play microwave sensor with 15 metre range, it's never been simpler to achieve significant energy savings while maintaining optimal lighting conditions. Say goodbye to wasted energy!

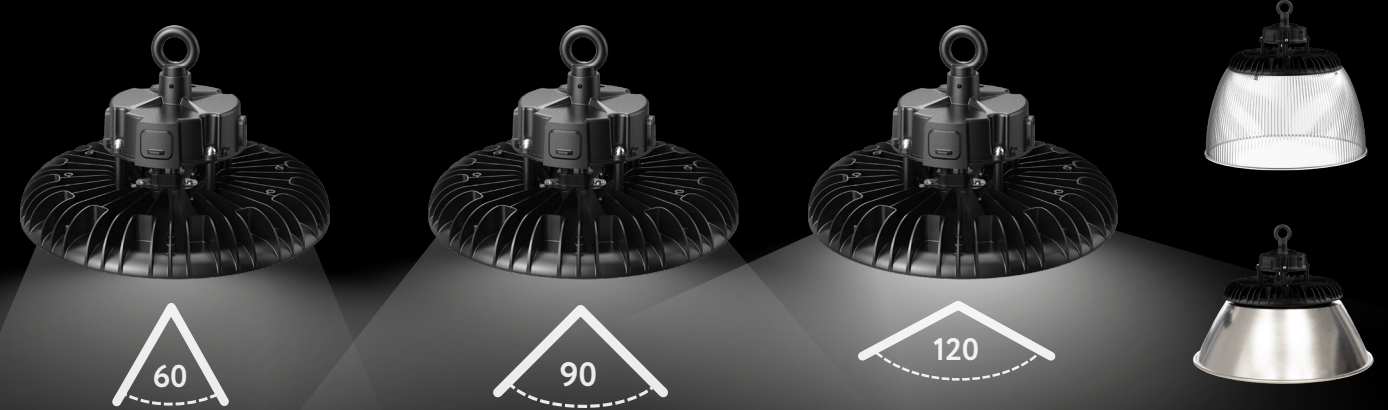

Multiple Beam Angle and Reflector Options

The Hartland offers three beam angles and two reflector options ensuring optimal usage of light based on individual needs and preferences.

Part No.	Watts	Description	Beam	Efficacy	Lumens	Ra/CCT
IND253-C10	80W / 120W / 150W	Hartland Highbay, 1-10V	120°	155	12800 / 18600 / 22250	840/850/857
IND253-C10-D60	80W / 120W / 150W	Hartland Highbay, 1-10V	60°	155	12800 / 18600 / 22250	840/850/857
IND253-C10-D90	80W / 120W / 150W	Hartland Highbay, 1-10V	90°	155	12800 / 18600 / 22250	840/850/857
IND257-C10	150W / 200W / 240W	Hartland Highbay, 1-10V	120°	155	24000 / 31000 / 36000	840/850/857
IND257-C10-D60	150W / 200W / 240W	Hartland Highbay, 1-10V	60°	155	24000 / 31000 / 36000	840/850/857
IND257-C10-D90	150W / 200W / 240W	Hartland Highbay, 1-10V	90°	155	24000 / 31000 / 36000	840/850/857

[View Full Specification Information Here](#)



Not Forgetting An **Emergency** Solution

No project is complete without considering your emergency solution and we've got you covered. Introducing our re-engineered Emergency Pod, featuring a Lithium battery and delivering a massive 1000 lumen output. Seamlessly integrate it into your existing wiring for hassle-free installation, ensuring effortless compatibility with most Highbays.

With this streamlined solution, optimise your operations and be ready to tackle any challenge with ease!



EASY INSTALLATION

Seamlessly integrate it into your existing wiring for hassle-free installation. Suitable for mounting at height with high brightness indicator always visible from the ground.



HIGH OUTPUT

With 1,000 lumen output this delivers three times more light than traditional industrial emergency solutions.



SELF-TEST

A 3 hour self-test on all fixtures provide peace of mind and hassle free maintenance.



LITHIUM BATTERY

A Lithium Battery ensures optimal performance for many years to come.



ROBUST DESIGN

A robust construction capable of handling weight and brash environments. As well as being light weight and universal.



ECONOMICAL

With less fittings required and less maintenance needed throughout product life meaning overall cost savings.

Part No.	Watts	Description	Ra/CCT	Weight (KG)	Dimensions (ø x H mm)
EMG063	6W	Emergency POD for Highbay, LiFePO4, Self-Test	865	1.6	130 x 300