

150 Watt HID Ballast

Ballast Code: HSF165192

Electrical Data (Ballast)	
Lamp Watts (W)	150
Lamp Current (A)	1.8
Input Voltage at 50Hz (V)	190/200/210/220/230/240
Input Voltage at 60Hz (V)	210/220/230/240/250/260
Circuit Watts (W)	175
Running Current (A)	0.8
Delta T (°C)	70
tw (°C)	130
ta (°C)	-
Thermal Cut-out	N
Capacitor Value (µf)	20/16
Capacitor Voltage (V)	250

Physical Data (Ballast)

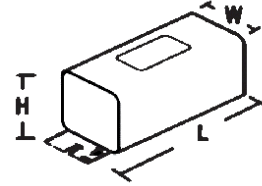

Dimensions (mm)	L	W	H
	172	92	90
Fixings (mm)	150-160		
Weight (kg)	3.4		

Timed Ignitor 220/240V ±10% 50/60Hz

Ignitor Code: PCX400255

Electrical Data (Ignitor)	
Wattage (W)	35-450
Timed	Y
Ignitor Type	Superimposed
Max Lamp Current (A)	5
Pulse Magnitude (kV)	3.5-4.5
Max. Lead Capacitance (pF)	100
Max Case Temp (°C)	105
Internal Temp (°C)	30

Physical Data (Ignitor)

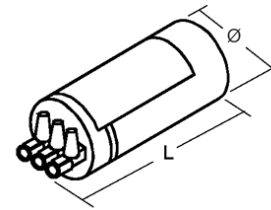

Dimensions (mm)	Ø	L	
	40	75	
Fixing	M8x10		
Weight (kg)	0.18		

Capacitor

Circuit Diagram

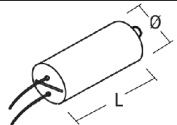
	
Value µf±10%	20.0
Product Code	20/250
Dimensions ØxL	35x98

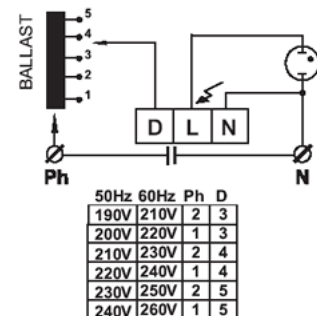

Notes:

Data is based upon tests performed by Venture Lighting in a controlled environment and is representative of relative performance. Actual performance can vary depending on operating conditions. Specifications are subject to change without notice.